

In December 2003, the Finnish electricity supplier TVO placed an order for the construction of the first EPR (European Pressure Reactor or European Pressurized Water Reactor) at Olkiluoto with the Framatome ANP/Siemens AG consortium. Framatome ANP, an AREVA and Siemens company, will supply the nuclear engineering (reactor), and Siemens AG the conventional engineering. In this report, Mr. Michael Herbstritt looks at the background of the development of the EPR and the role of AUMA actuators in this next generation nuclear power plant.

Electric actuators for use in nuclear power plants

By Michael Herbstritt, AUMA Riester GmbH & Co. KG, Germany

In a brochure entitled 'The EPR, Committed to the Future of Nuclear Energy', AREVA - one of two partners involved in the development of this new and advanced type of pressurised water reactor details the technological advances of the EPR's evolutionary, safe and innovative design. The improved safety concept compared to that of the currently operated nuclear power plants is very important for the sustainability of this new reactor type. For safe operation and control of fault conditions (DBE), it is paramount that the valves can be reliably opened or closed under all operation conditions to ensure control of the energy flow within the system. This puts the highest demands on the actuators for operation of the valves.

What is an electric actuator?

Before looking at the specific standards, application classifications and EPR requirements that have impacted the role of the actuators, we look first at the design of the electric actuator to better understand its function within the EPR.

Actuators are geared motors which have been specially designed for the requirements in valve automation.

- Due to its design, the electric motor, usually a three-phase asynchronous motor, has a high starting torque to unseat valves from their end position.
- A worm gearing reduces the motor speed to the output speed required at the valve stem.
- The actuator is mounted on the valve using valve attachments in

accordance with EN ISO 5210.

- The control unit includes two independent measuring units for measuring the travel and the torque present at the valve. When reaching one of the valve end positions or exceeding the set torque limit, the respective electromechanical switch is operated. Depending on the valve type, the actuator is switched off in the end positions via the limit or the torque signal. To this end, the signals have to be >>

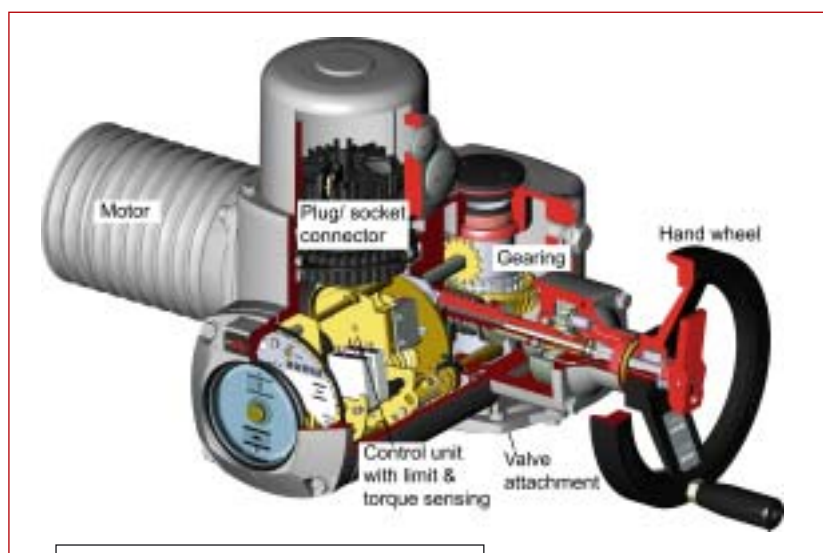

Figure 1: Typical design of an electric actuator

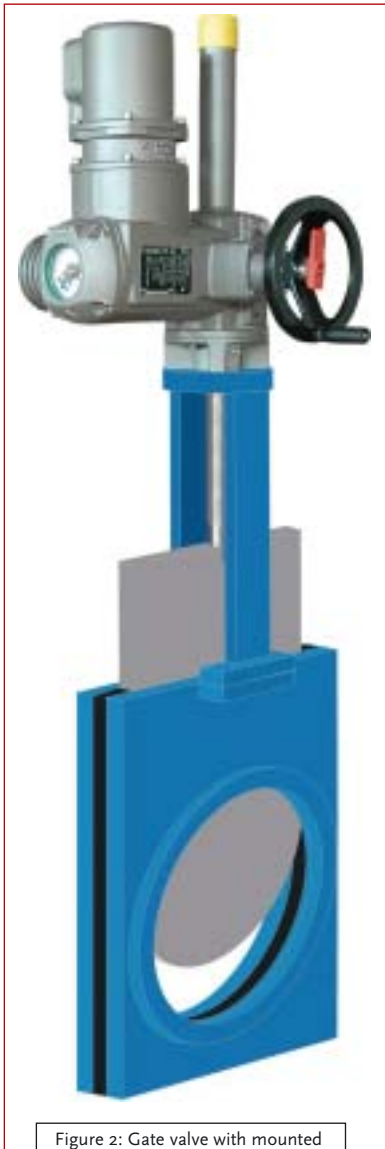

Figure 2: Gate valve with mounted multi-turn actuator

processed accordingly in the superordinate controls.

- A handwheel is used for the manual operation of the actuator. Manual operation is activated via a

manual change-over mechanism.

- The electrical connection is either made via terminals or via a plug/socket connector. The plug/socket connector enables quick dismantling of the actuator, e.g. for maintenance purposes.

Multi-turn, part-turn and linear movements

These are the three basic movements which are, depending on the valve type, used for the operation of the closing element.

- Gate valves are classic representatives of multi-turn valves. The output hollow shaft in the actuator transmits several turns to the valve stem to run the valve stem from OPEN to CLOSE and vice versa. A multi-turn actuator is required to automate this valve type.
- If less than one complete turn is required for full travel, the valve is called a part-turn valve. Butterfly valves or ball valves are typical representatives of this specific valve type. For these valves, the closing element and therefore the valve shaft perform a 90° swivel movement when operated from OPEN to CLOSE. These valves are operated by means of part-turn actuators.
- Diaphragm or globe valves are opened or closed via a thrust movement. Therefore an actuator

is required which performs a linear movement.

Open-close or modulating duty

If valves are used as shut-off devices, this is called OPEN-CLOSE duty. Valves can also be used for flow control. The desired flow is set by adjusting the closing element. This is called modulating duty. Contrary to shut-off valves, which are only rarely operated, the valve position of modulating valves has to be readjusted at short regular intervals due to changing conditions or new setpoint values. This requires a high number of starts and is decisive for the selection of a suitable actuator. To be able to meet the higher requirements of modulating duty, an actuator for modulating duty must be used.

Standards for actuators in nuclear power plants

The requirements on actuators for use in safety-related areas in nuclear power plants are stipulated in special standards. For the EPR, actuators are approved which are qualified in accordance with the American IEEE 382, the German KTA 3504 or the French RCC-E 2000.

Classification of the applications within the EPR

Depending on the location within the nuclear power plant and the safety-

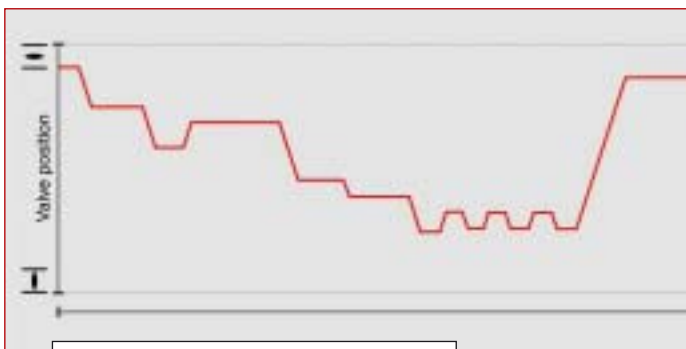

Figure 3a: Typical operation in open-close duty

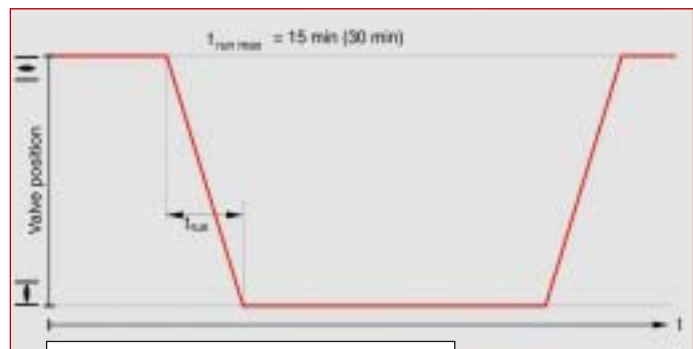

Figure 3b: Typical operation in modulating duty



Figure 4: Cross-sectional view of the EPR

related functions of the actuator's respective valves to be automated, the six application categories for actuators in the EPR are defined as follows.

- A1 Actuators without nuclear safety-related functions. These actuators are used in for example the turbine building. The conditions within this area correspond to the conditions in a conventional power plant.
- A2 Same as A1 plus the additional proof of seismic stability. In case of an earthquake, the device must maintain its integrity.
- A3 Actuators with this classification must work properly during and after seismic stresses. These actuators are used in for example the auxiliary buildings outside containment.
- A4 In addition to the seismic stresses, the actuators have to withstand the radiation under fault conditions (DBE). These actuators are used for the EPR in safety buildings and the fuel element storage area, for example.
- A5 Actuators of this category are designed for use inside contain-

ment. The actuators must retain their function during and after seismic stresses and under LOCA (loss of coolant accident) conditions (i.e. extreme pressure, temperature, humidity, and radiation conditions). The actuator design has to prevent the ingress of humidity under defined pressure and humidity conditions.

A6 Same as A5 with operability after long-term LOCA conditions.

The present EPR classification must be matched with the requirements in the standard. The EPR consortium and the actuator manufacturer agreed on using the requirements of IEEE 382. This standard classifies actuators for use inside containment and outside containment according to their safety-related functions (oE without, 1E with safety-related functions). Safety-related function means that the performance of the equipment under fault conditions (DBE) must be ensured. The following was stipulated for the EPR:

Conventional actuators with oE classification are used for A1 and A2 applications.

Outside containment duty actuators with 1E classification according to IEEE 382 are used for A3 and A4 applications. Inside containment duty actuators with 1E classification according to IEEE 382 are used for A3 and A4 applications. >>



Figure 5: Multi-turn actuators of the SAI type range (inside containment, 1E classification)

Additional EPR requirements

The specification requires the use of actuator type ranges whose suitability has been proven during many years of use. The use of prototypes is generally excluded. To prevent the ingress of humidity via the line bushings into the actuator, the electrical connection for A5 and A6 actuators is made via special DBE resistant cable entries. Connection possibilities for these large-volume, encapsulated line bushings have to be provided at the actuators. The electrical connection is generally made as plug-in connection to enable easy inspection and to exclude wiring faults when reconnecting the cables.

Qualification of the actuators

A1 and A2 actuators are actuators which may also be used in non-nuclear plants. For A2 actuators, a calculatory proof for the flange connection to the valve is required to prove resistance to seismic stresses. For those actuators having to retain their functions under LOCA conditions, the qualification procedure is very extensive. The example provided in figure 5 shows the qualification procedure according to IEEE 382 for LOCA actuators to be used inside containment. The loads put on the devices are extremely high.

AUMA actuators in nuclear power plants

In conclusion, not only the requirements on products for use in nuclear power plants are high but also the demands on the qualification of the manufacturers. The EPR consortium was looking for an actuator manufacturer

- with several years of experience in the processing of nuclear power

plant projects and in dealing with the respective standards.

- with certified multi-turn, part-turn and linear actuators for open-close and modulating duty with long-term operational reliability.
- an ability to offer devices for the different EPR categories.
- having a certified quality management system.

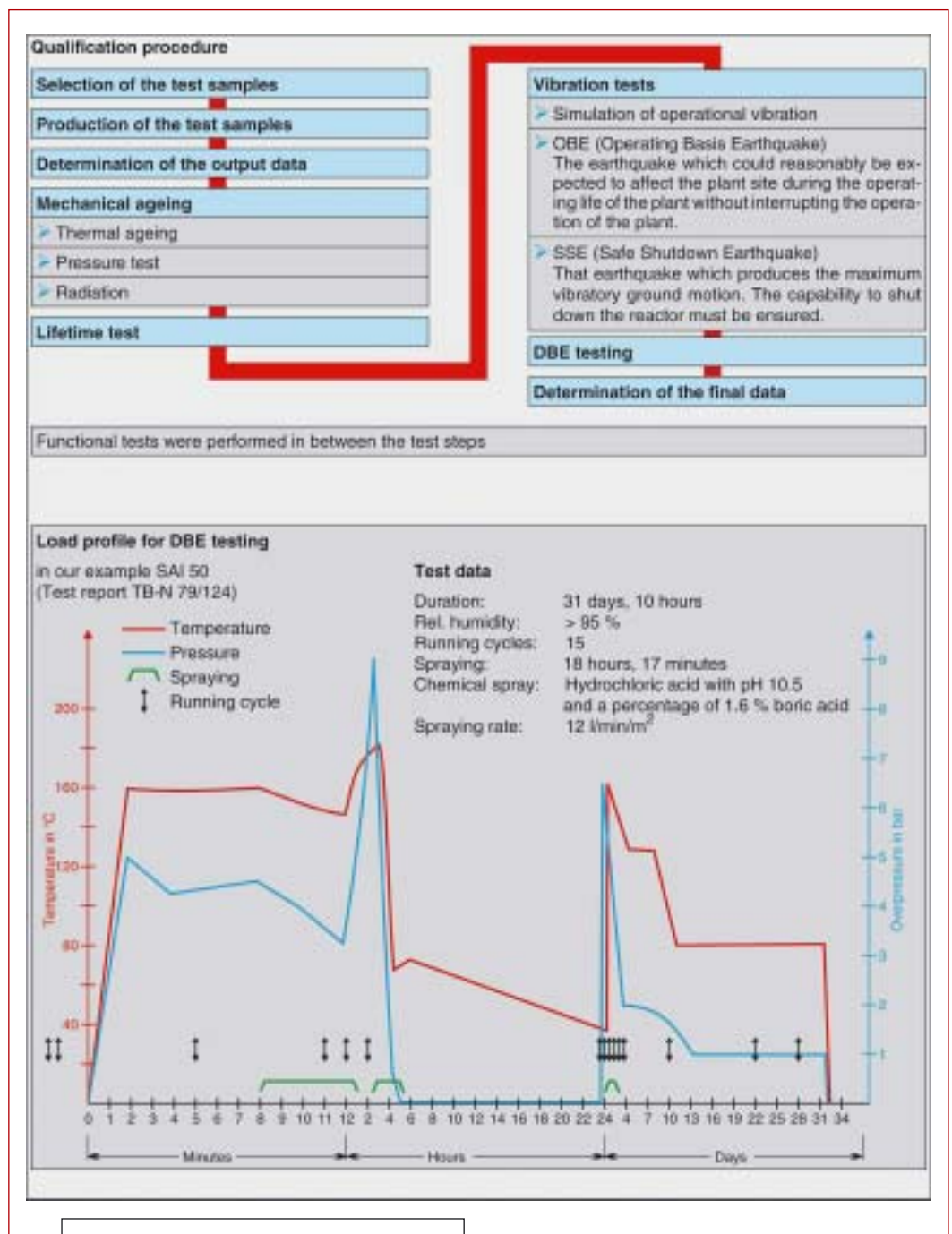

Figure 6: LOCA test for the multi-turn actuator SAI



Figure 7: Combination of multi-turn actuator SAI with part-turn gearbox GSI = part-turn actuator

duty and for modulating duty. By combining them with the, also qualified, part-turn gearboxes or linear thrust units, actuators for the automation of part-turn and linear gearboxes are available as well. Due to the worldwide AUMA service network, service technicians are available on site – in the case of Olkiluoto and TVO, the Finnish AUMA subsidiary OY AUMATOR is responsible. ■



Figure 8: Combination of multi-turn actuator SAN with linear thrust unit LEN = linear actuator

- offering comprehensive project support. This includes sizing of the devices, on schedule delivery, installation and commissioning of the actuators and finally inspection and maintenance services.

AUMA meets all these requirements. Since 1978, AUMA has manufactured

actuators for the use in nuclear power plants. With the multi-turn actuator types SAI (inside containment, 1E) and SAN (outside containment, 1E), AUMA can supply two qualified and well-proven actuator types meeting the requirements of the classifications A3 to A6. The actuators are available in a version for open-close

About the author



Michael Herbstritt is a technical writer for AUMA Riester GmbH & Co. KG, one of the leading manufacturers of electric actuators worldwide, at the company's headquarters in Muellheim, Germany (Baden-Württemberg). Within the framework of his tasks, he has been writing product documentation as well as technical articles for 10 years now and has been conducting customer training and

providing product information on electric actuators. He graduated from Karlsruhe University with a degree in electronic and electrical engineering (Diplomingenieur). During his studies, the main focus was on the generation and distribution of electrical energy. After graduation, he did research work on wind power plants at the Fraunhofer Institute for Solar Energy Systems for two years before starting with AUMA Riester GmbH & Co. KG and changing from a public institute to a private enterprise in 1995.